



RHINO-RACK

Aerodynamic & Heavy Duty Roof Rack Systems

43106 / 43117 - Eye Bolt Pioneer Alloy Tray (2) (3)

Place these instructions in the vehicle's glove box after installation is complete.

Important: Please read these instructions carefully prior to installation.
Please refer to your fitting instruction to ensure that the alloy tray is installed correctly.
Check the contents of this kit before commencing fitment and report any discrepancies.

Item	Component Name	Qty (43106)	Qty (43117)	Part No
1	M10 Eye Bolt	2	3	C013
2	M10 Shakeproof Washer	2	3	W021
3	M10 x 38 x 2.5mm Flat Washer	2	3	W022
4	M10 x 30 x 2.5mm Flat Washer	2	3	W023
5	M10 Plate Nut	2	3	N061
6	Fitting Instruction	1	1	RR248

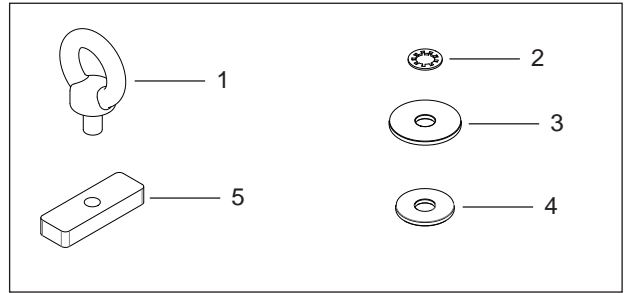

1 Assemble Hardware

Assemble hardware as shown with the thread of the eye bolt engaging only 2-3 turns.



Assembled View

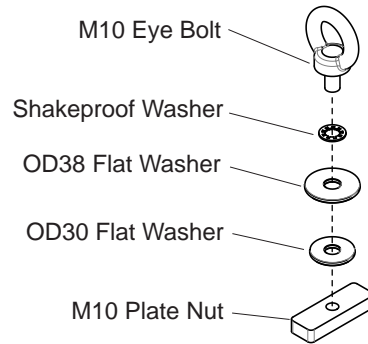

2 Fit Eye Bolt to Plank

Lower the eye bolt assembly into the slot at the front of the plank as shown, the plate nut should be sitting within the C channel of the plank. Slide the eye bolt along the plank to the desired position. Secure the eye bolt in place by sliding a screwdriver through the eye of the bolt and rotate clockwise to tighten.

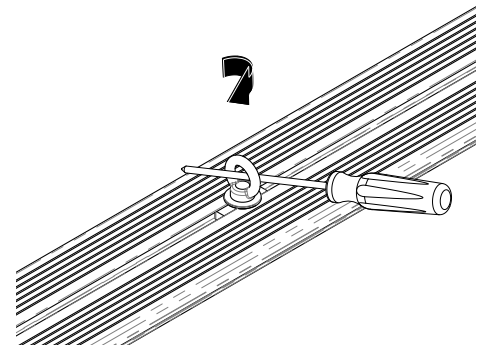
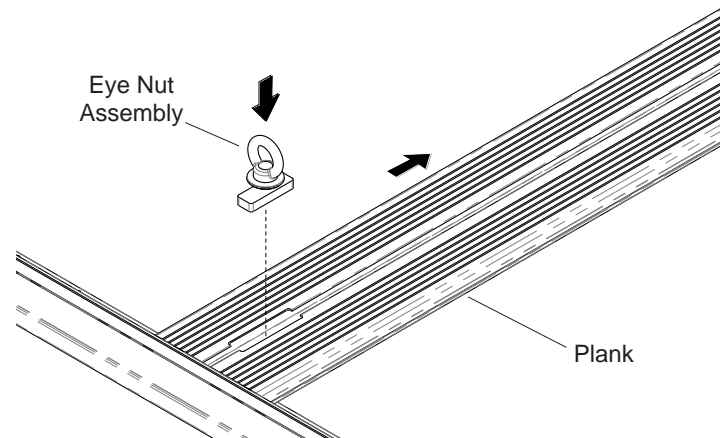

Rhino-Rack
3 Pike Street, Rydalmere,
NSW 2116, Australia.
(Ph) (02) 9638 4744

Document No: RR-248
Prepared By: Andy Wana
Authorised By: Chris Murty

Issue No: 02
Issue Date: 27/09/2011

These instructions remain the property of Rhinorack Australia Pty Ltd and may not be used or changed for any other purpose than intended.